

## ASSEMBLY INSTRUCTIONS – No. 1187 Ten-Battery Merchandiser

**NOTE:** Read through these instructions once before starting assembly, then return to Step (1) and proceed as directed.

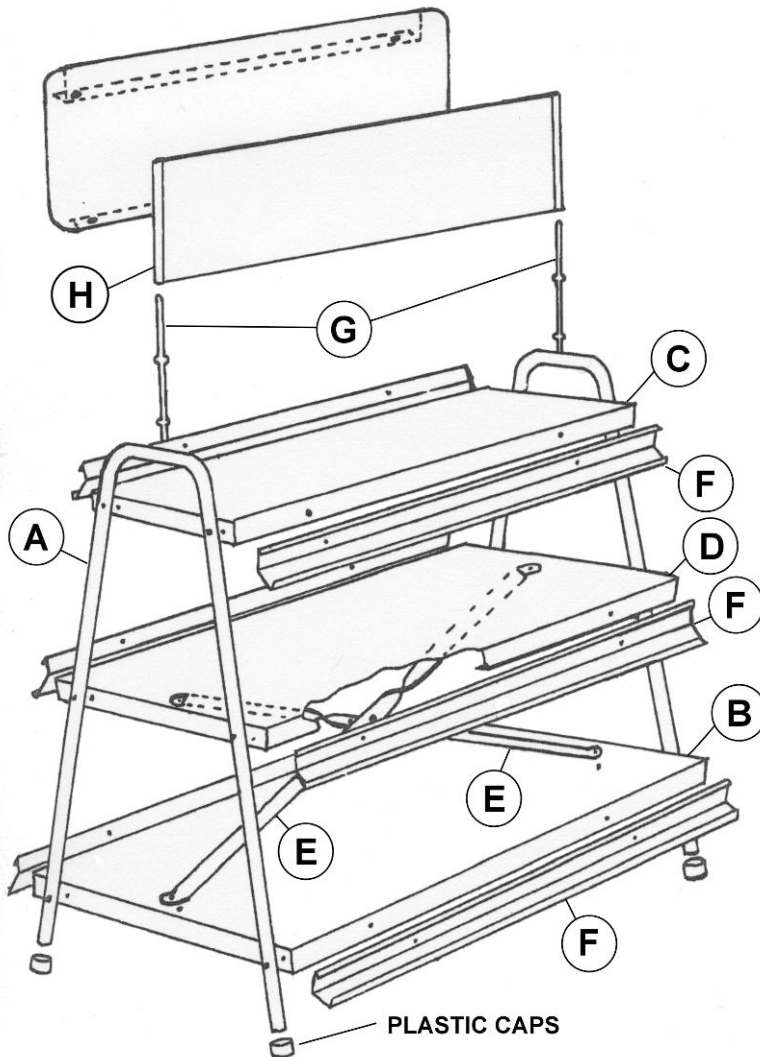

- (1) Put Plastic Caps on ends of Frames (A).
- (2) Fasten Bottom (largest) Shelf (B) between Uprights with four long bolts and nuts. **DO NOT TIGHTEN NUTS COMPLETELY AT THIS TIME** — they should be left loose enough to shift until assembly is complete.
- (3) Attach Top Shelf (C) and Middle Shelf (D) in the same manner.
- (4) Bolt the ends of Braces (E) to the underside of the Middle Shelf with two short bolts and nuts; fasten the center of these Braces with another short bolt and nut to form an X-ABrace and then fasten to the top of Bottom Shelf. **TIGHTEN ALL BOLTS.**
- (5) Label Tracks (F) are optional and **HAVE BEEN INCLUDED ONLY IF ORDERED.** If they're included, fasten to faces of each Shelf with two tapping screws each.

- (6) Sign and Sign Pins are also optional, and **HAVE BEEN INCLUDED ONLY IF ORDERED.** If included, Sign may have curled ends or may be flanged at top and bottom. In either case, drop the short end of Pins (G) into holes at the top of each Frame, then put Sign (H) down over Pins.

In case of parts shortages or defects, describe missing or defective part by name and letter designation used in these instructions, and report direct to the manufacturer.

**WARREN STEEL SPECIALTIES CORPORATION**

P.O. Box 1391 Warren, Ohio 44482

(330) 399-8360