

ASSEMBLY INSTRUCTIONS – NO 1326 NINE-BATTERY RACK

NOTE: CAREFULLY EXAMINE THE ILLUSTRATION AND READ THROUGH THESE INSTRUCTIONS BEFORE STARTING ASSEMBLY, THEN PROCEED AS FOLLOWS:

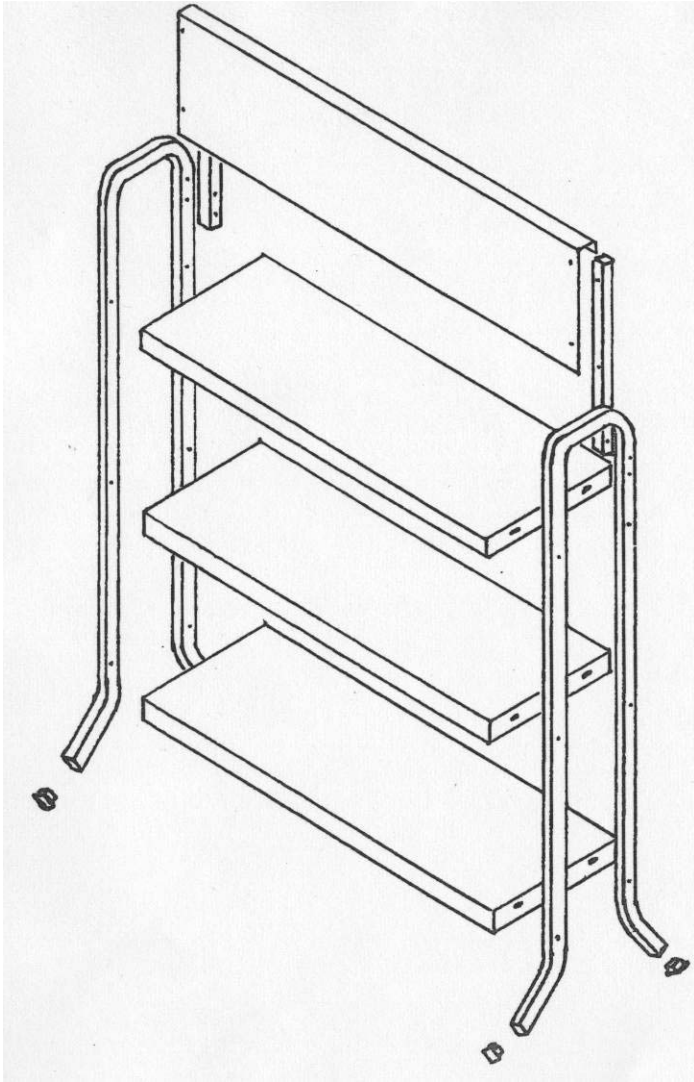

- (1) Tap Plastic Plugs into open ends of Frames.
- (2) Attach Shelves between Frames with the shorter length screws; making sure that the Sign Post holes are towards what will be considered the rear of the rack. APPLY THE NUTS BUT DO NOT TIGHTEN.
- (3) Sign Posts and Sign are optional, and have been included only if ordered. If included, attach Sign Posts to the insides of the Frames using the longer length screws. APPLY NUTS BUT DO NOT TIGHTEN.
- (4) Slip the Sign over the Sign Posts and line up the holes in the Sign with the holes in the Sign Posts. Apply a nylon washer to each of the (4) remaining shorter length screws and insert them into the Sign holes from the front of the Sign. APPLY NUTS BUT DO NOT TIGHTEN.

- (5) Place the rack on a level surface and tighten all fasteners, making sure that the sign Posts are lined up vertically with the Frames.

In case of parts shortage or defects, describe missing or defective part by its name used in these instructions, and report to the manufacturer:

WARREN STEEL SPECIALTEIS CORPORATION
P.O. Box 1391 Warren, Ohio 44482
(330) 399-8360