

## ASSEMBLY INSTRUCTION – No. 1478 Tire Rack

CAREFULLY EXAMINE THE ILLUSTRATION AND READ THROUGH THESE INSTRUCTIONS BEFORE BEGINNING ASSEMBLY, THEN PROCEED AS FOLLOWS:

- (1) Using the longer bolts fasten Rails (A) to Frames (B). Apply nuts but do not tighten.

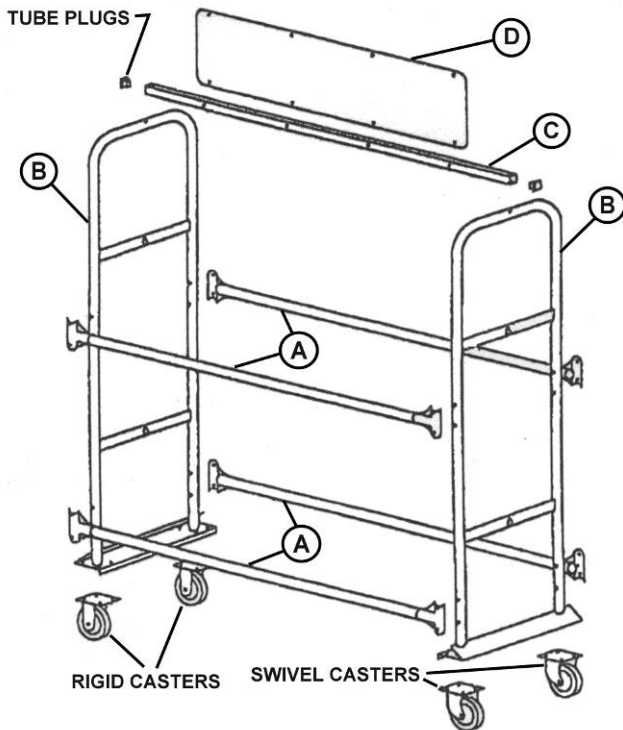

- (2) Using the shorter bolts attach the Casters to the bottoms of the Frames so that the Rigid Casters are on one end and the Swivel Casters are on the other end.

NOTE: Your order may have called for a swinging sign; if so, follow the instructions for that assembly to install the swinging sign, and then go to Step (4) below. If your order called for the stand-up sign as shown here, proceed with Step (3) below.

- (3) Insert Tube Plugs into the ends of Sign Bar (C) and fasten Sign (D) to the Sign Bar, using the four small bolts and nuts provided. Place this assembly on top of Frames, fastening with the two remaining bolts and nuts.
- (4) With the rack standing on a level surface, **TIGHTEN ALL FASTENERS.**

- (5) If your rack has been ordered with the optional Locking System, install as follows after your display tires have been placed on the rack:

Insert straight ends of the Locking Bars through keyhole slots in the crossbars at one end of rack, then run through each tier of tires and corresponding slots at the other end. Rotate lower bar up so the slots in both bars are together, then secure with padlock.

In case of parts shortages or defects, describe missing or defective part by name and letter as used in these instructions, and report to the manufacturer:

WARREN STEEL SPECIALTIES CORPORATION  
P.O. BOX 1391 Warren, OH 44482  
(330) 399-8360