

ASSEMBLY INSTRUCTIONS – NO. 1806 Swinging Sign and Sign Bar Kit
(For No. 1278 or No. 1804 Tire Display Rack)

IMPORTANT:

FASTENERS, TEE CONNECTORS, AND POSTS (if required) ARE PACKED INSIDE THE FOLDED SIDE OF THIS CARTON. DO NOT DISCARD THE CARTON UNTIL THESE PARTS HAVE BEEN REMOVED.

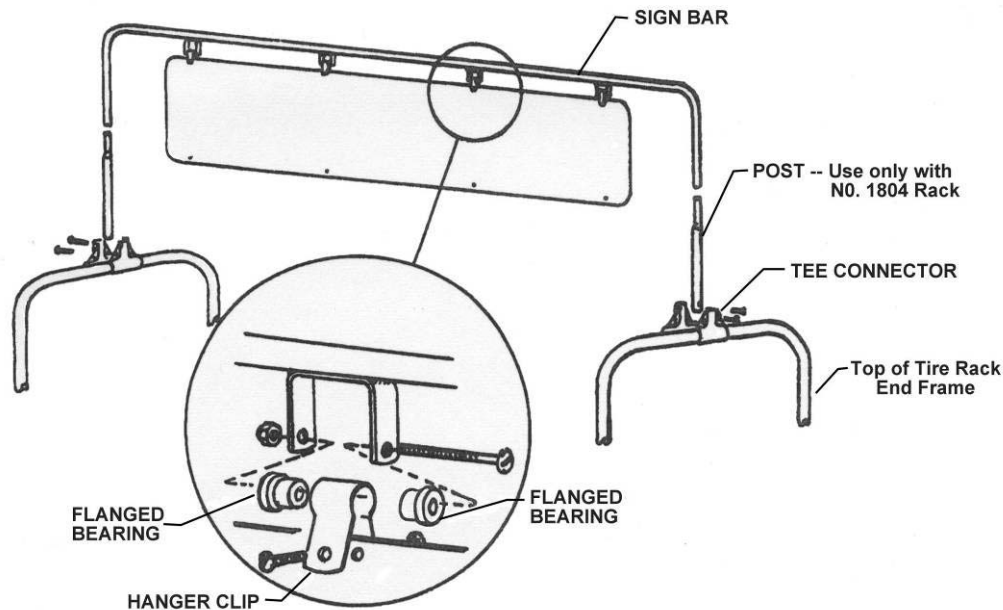

- (1) Attach HANGER CLIPS to each of the four clevises on SIGN BAR, inserting a FLANGED BEARING from each side of the Clip. Fasten with long bolts and locknuts. Refer to the enlarged (circled) illustration above for details of this assembly.
- (2) Attach the SIGN between the open ends of the Hanger Clips, using short bolts and locknuts.

NOTE: If this sign kit is to be mounted on a No. 1804 (or 1804-S) Rack, continue with steps (3) and (4) below and ignore step (5). If for No. 1278 or 1278-S or -LS Rack, skip steps (3) and (4) and go to step (5).

- (3) Assemble two TEE CONNECTORS and one POST on the top of each rack frame, as shown above. Be sure the LARGE end of each post is facing DOWN. Leave nuts slightly loose.
- (4) Slide the open ends of the Sign Bar assembly down over the reduced upper ends of Posts. Shift each Post and Tee Connector as necessary to locate Sign over center of Rack, then tighten Tee Connector nuts.

TO MOUNT SIGN KIT ON NO. 1278 (or 1278-S or -LS):

- (5) Assemble two TEE CONNECTORS on the top of each tire rack frame, and around each leg of the Sign Bar. (Note that no Post is required). Shift as necessary to position Sign over the center of the Rack, then tighten the Tee Connector nuts.

In case of parts shortages or defects, describe missing or defective part by name and letter as used in these instructions, and report to the manufacturer:

WARREN STEEL SPECIALTIES CORPORATION
P.O. BOX 1391 Warren, OH 44482
(330) 399-8360